

303B Moisture Monitor

HIGHLY ACCURATE PORTABLE MEASUREMENT OF TRACE MOISTURE IN GAS STREAMS FOR DIVISION 2 AREAS

Moisture in gas streams has a way of causing trouble in manufacturing operations and in many research and quality control procedures. Since moisture affects the chemical, electrical, and physical properties of virtually everything, undetected or unchecked moisture can adversely affect product quality and reduce or halt production.

DESCRIPTION

The 303B offers a simple solution to the problem of measuring the moisture content of gas streams. Based on Faraday's Laws of Electrolysis, the 303B absorbs and electrolyzes moisture down to fractional parts-per-million and is linear to its 2000 parts-per-million-by-volume maximum reading. An electrolytic cell does not require calibration and is virtually specific to water so it can be used to monitor nearly all gases.

The 303B is equipped with a digital moisture indicating meter, all solid state electronics, a rugged plug-in moisture cell, and a highly accurate, adjustable flow control system. The unit is compact, lightweight, and suitable for both portable use and permanent installation.

A 4-to-20 mA output, compatible with 625-ohm maximum load, transmits moisture level to a recorder or control center. This allows the analyzer to be situated close to the sample tap to give fast and accurate measurement.

The 303B is available with a choice of power sources covering AC, external DC, and internal battery operation. With an optional carrying bag and lightweight design, this flexibility makes the 303B truly portable.

A built-in bypass flowmeter increases total sample flow to reduce response time. This bypass feature is valuable when the 303B is in portable service—for example, rapidly analyzing moisture in gas cylinders, where it is essential to purge valves, regulators, and tubing of atmospheric moisture prior to taking measurements.

APPLICATIONS

The portable 303B Moisture Monitor, built for NEC Division 2 areas, is designed to measure moisture content in gases



Portable, Digital Display, Highly Accurate, Proven Performance, No Calibration Needed

such as air, nitrogen, argon, natural gas, and others with comparable characteristics. Typical 303B applications are:

- Monitoring natural gas pipelines and gas treatment processes
- Monitoring air humidity in dry boxes
- Continuous monitoring of atmospheres in simulated space chambers
- Sensing elements in humidity control systems
- Monitoring inert protective atmospheres in brazing or sintering furnaces
- Monitoring moisture in many fluorocarbon gases
- Constant measurement of batch and continuous driers to assure quality control without the expense of overdrying
- Monitoring anhydrous batch chemical processes at startup
- Quality control of transistor and diode backfill gas
- Instrument air systems
- Cryogenic processes
- Radar waveguides

PERFORMANCE SPECIFICATIONS

Dynamic Range: 0 to 1000 ppmv at 100 mL/min. sample flow through cell at 25°C and 101.4 kPa (0-2000 ppmv range possible with reduced sample flow)

Sensitivity: 0.1 ppmv

Accuracy: ± 0.5 ppm or $\pm 5.0\%$ of the display reading, whichever is greater

Response Time: 63% response to a stepwise change in either direction between 50 ppm and 1000 ppm will occur in 30 seconds or less

Utility Requirements: 100 to 130 VAC or 200 to 260 VAC (select required model from table of Ordering Information on page 3) and optional 12 to 14 VDC* operation, 20 W maximum

Analog Output: 4-to-20 mA DC proportional to range selected, compatible with 625-ohm maximum load

Alarms: Rated for 1 A, 24 VDC, normally open and normally closed contacts; user-settable to fail-safe or low-power operation

Sample Temperatures: up to 52°C (125°F)

Ambient Temperatures: 0° to 52°C (32° to 125°F)

Temperature Stability: 0.5% per °C of selected range

Sample Pressure: 69 to 690 kPa (10 to 100 psi) gauge

Approvals and Certifications

UL/CSA General Safety Requirements

UL/CSA Class I, Division 2, Groups A, B, C, D T4A

Complies with all relevant European directives

MECHANICAL SPECIFICATIONS

Electrolytic Cell: Provided in a self-contained cartridge that can be replaced in seconds. Sample connections are made automatically when the cell is inserted. Electrical connections are made through wires and a two-pin plug.

Front Panel Controls: Analog ranges 0 to 10, 100, 1000, and 2000 ppm; 0 to 0.5, 5, 50, 100 lb./mmscf

- Display light
- Alarm
- Standby power
- Electrical test
- Cell test
- Power
- Sample and Bypass Flow adjust

External Connectors: Gas IN and OUT fittings for 1/8 inch OD tubing. Internal connections for output and alarms; relay jumper changes operation to failsafe mode.

Materials of Construction: Sample comes in contact with P₂O₅, stainless steel, TEFLON® fluorocarbon resin, glass, platinum, and Viton.

Weight: 6.4 kg (14 lb.)

Cabinet Dimensions (L x W x H): 34.3 x 23.5 x 12.7 cm (13.5 x 9.25 x 5.0 in.)

** All units provided with an automotive-style power cable.*

LIMITATIONS

Most gases or vapors may be analyzed for moisture with the 303B. However, some compounds are known to reduce instrument performance.

● Hydrogen and oxygen in sample

Can recombine to form moisture, causing an incorrect reading. This effect can easily be determined and corrected by a simple procedure outlined in the operating manual.

● Unsaturated hydrocarbons (except aromatics)

Tend to polymerize in detector cell, shortening cell life.

● Light alcohols

Water splits off molecule causing instrument to read high.

● Amines and ammonia

React with P₂O₅ coating in cell, use not recommended.

● Fluorine and hydrogen fluoride, chlorine and hydrogen chloride

React with materials of construction, use not recommended.

ACCESSORIES

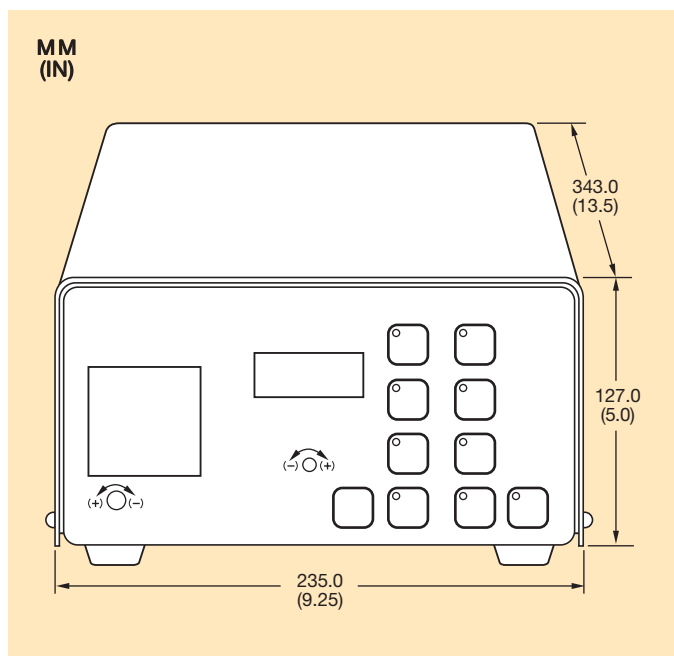

- **Oil Separator—Catalog No. 303165901**
For use at inlet when sample is likely to contain entrained oil mists
- **Bubble-O-Meter—Catalog No. 303030006**
Laboratory device for precision measurement of sample flow rate
- **Low Pressure Accessory—Catalog No. 203269001 (110 V); 203269002 (220 V)**
Stainless steel bellows pump used when sample pressure is less than 69 kPa (10 psi) gauge. Power required: 160 watts. Inlet and outlet port size 1/8 inch NPT. Weight 2.5 kg (5.5 lb.)
- **Pressure Reducing Assembly—Catalog No. 510150901**
Used for sampling gases at pressures of 690 kPa (100 psi) gauge to 20,700 kPa (3000 psi) gauge. Made of stainless steel, the assembly is supplied ready to install, complete with outlet gauge and relief valve.

ORDERING INFORMATION

When ordering, specify part number and model number.

EXAMPLE: Part Number 303B-STD

Model Number 3 - - -

01 = ppm version
02 = lb./mmscf version

05 = 100 to 130 VAC
06 = 200 to 260 VAC

1 = Basic 303B
2 = Includes a carrying case

One of a family of innovative process analyzer solutions from AMETEK Process Instruments. Specifications subject to change without notice.

USA - Pennsylvania
150 Freeport Road
Pittsburgh, PA 15238
Ph. 412-828-9040
Fax 412-826-0399

USA - Delaware
455 Corporate Blvd.
Newark, DE 19702
Ph. 302-456-4400
Fax 302-456-4444

CANADA
2876 Sunridge Way N.E.
Calgary, AB T1Y 7H9
Ph. 403-235-8400
Fax 403-248-3550

**MANUFACTURING
LOCATIONS**

AMETEK®
PROCESS INSTRUMENTS
www.ametekpi.com
© 2004, by AMETEK, Inc. All rights reserved.
303B (02/23/04)

**SUPPORT
LOCATIONS**

USA - Texas
Ph. 281-463-2820
Fax 281-463-2701

CHINA - Beijing
Ph. 86-10-85262111
Fax 86-10-85262141

CHINA - Shanghai
Ph. 86 21 6426 7049
Fax 86 21 6426 7054

FRANCE
Ph. 33 1 30 68 69 20
Fax 33 1 30 68 69 29

GERMANY
Ph. 49 21 59 91 36 0
Fax 49 21 59 91 3680

MIDDLE EAST - Dubai
Ph. 971-4-881 2052
Fax 971-4-881 2053

SINGAPORE
Ph. 65-6484-2388
Fax 65-6481-6588